



## **Battery Powered Application Tips**

### **Bulletin**

#### **Summary / Overview**

This document gives a brief overview of the environmental factors affecting the performance and life expectancy of Masterflux Variable Speed motor controls. Variable Speed drives are electronic devices applied in residential, commercial, and industrial environments to vary the speed of A/C compressor. The variable speed drive can be adversely affected by excessive voltage or current ripple on the input power terminals. If a variable speed drive is exposed to these adverse factors, the drive may exhibit any or all of the symptoms listed below:

- Erratic behavior
- Excessive faults
- Internal fuse failure
- A shortened life span

#### **Factors affecting the performance of Variable Speed Drives**

The power quality at an installation can be related to a number of factors. Some examples are:

- Over & under voltage, sags & surges, voltage imbalance.
- Electrical noise, impulses, voltage distortion and transients.
- Grounding and wiring termination.

Power quality varies from site to site due to the unique characteristics of each installation. Therefore, if you want to know with certainty what the power quality is at an installation, you must measure power quality at the point of use. Masterflux recommends that the input voltage and current be measured at the input power terminals of the controller. Excessive current ripple can cause internal heating of the controllers input filter capacitors and have significant impact on the controller's life span. See typical application diagram 1.0.

Typical current and voltage ripple should not exceed 20% of the maximum voltage and current rating of the Masterflux motor controller.

Contact Masterflux sales representative for additional information.

### Addressing the root problem(s) of power quality

Battery load and voltage varies from application, demand and load. In some situations the instantaneous current demand can be more than what the battery can supply. With high current demand the battery voltage can droop at which point the current will be supplied from the lowest impedance source which in some cases is the bulk filter capacitors on the Masterflux motor controller. In these extreme cases the energy stored in the bulk capacitors is discharged to supply the demanding needs of other power elements in the system. Once the current demand is satisfied the battery voltage rises which then charges the bulk capacitors. This constant charge and discharge of the motor controller's bulk filter capacitors affects the controller's performance and life expectancy.

In extreme cases where the input power voltage/current ripple has negative impact on controller performance a diode can be installed to help reduce the ripple affect on the motor controller. (see diagram 1.0)

### Techniques used to help prevent excessive current / voltage ripple

- Star point wiring at battery source to reduce line impedance.
- Optional series diode to stop discharge of capacitors. (see figure 1.0)
  - Typical diode: Powerex - CS240650 – Diode Module, 600V, 50A, POW-R-BLOK
- Battery selection

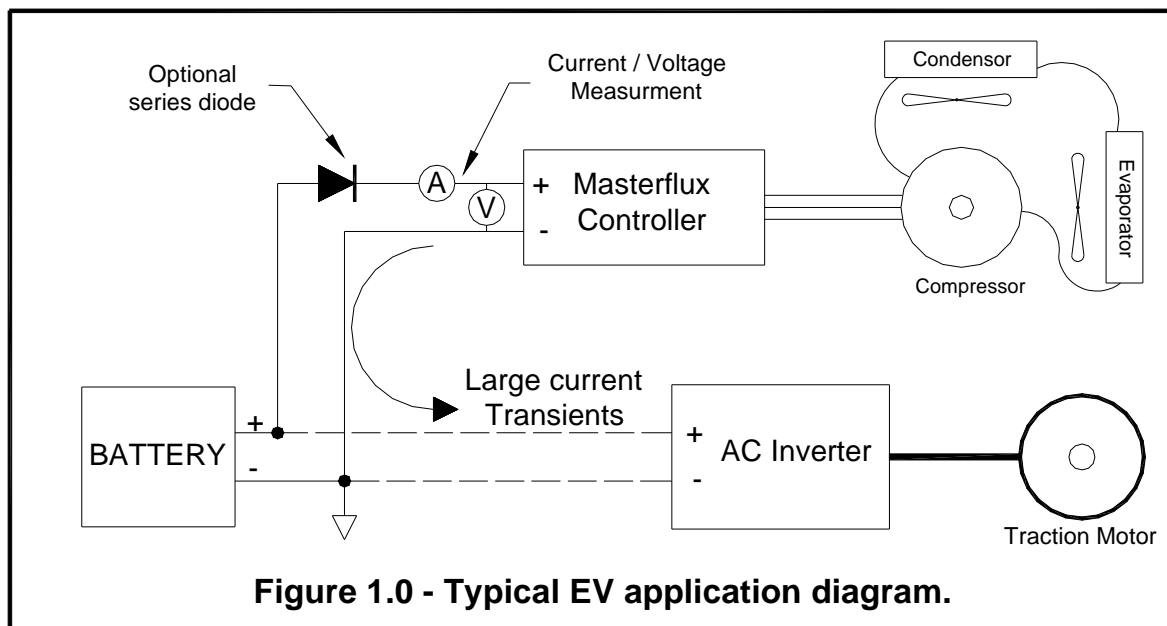

**Figure 1.0 - Typical EV application diagram.**