



MASTERFLUX

SIERRA03-0982Y3 High Capacity Brushless DC Variable Speed Compressor Technical Data Sheet

General Information

Compressor Part Number - Accumulator (81.6 cc)
Sales Compressor Drawing
Sales Controller Drawing
Wiring Diagram

SIERRA00035
DCMX01-004
DGMX002
DEMX04

Application Information

Application	HBP, A/C
Refrigerant	R134a
Voltage Range	22-50V DC
Evaporator Temperature Range	-23.3° C to 12.8° C (-10° F to 55° F)
Condenser Temperature Range	26.7° C to 65.6° C (80° F to 150° F)
Maximum Discharge Temperature	130° C (265° F)
Maximum Compression Ratio	8:1

Compressor Dimensions

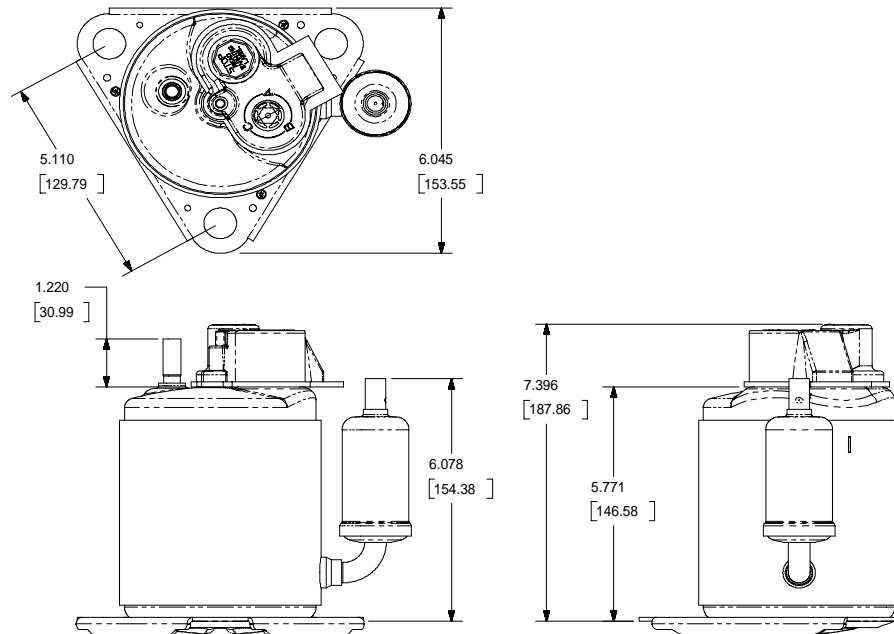

the Sierra



MASTERFLUX

SIERRA03-0982Y3 High Capacity Brushless DC Variable Speed Compressor Technical Data Sheet

Controller Features

- Over/under voltage protection
- Compressor thermal monitoring
- Controller thermal monitoring
- Locked rotor protection

Controller Dimensions

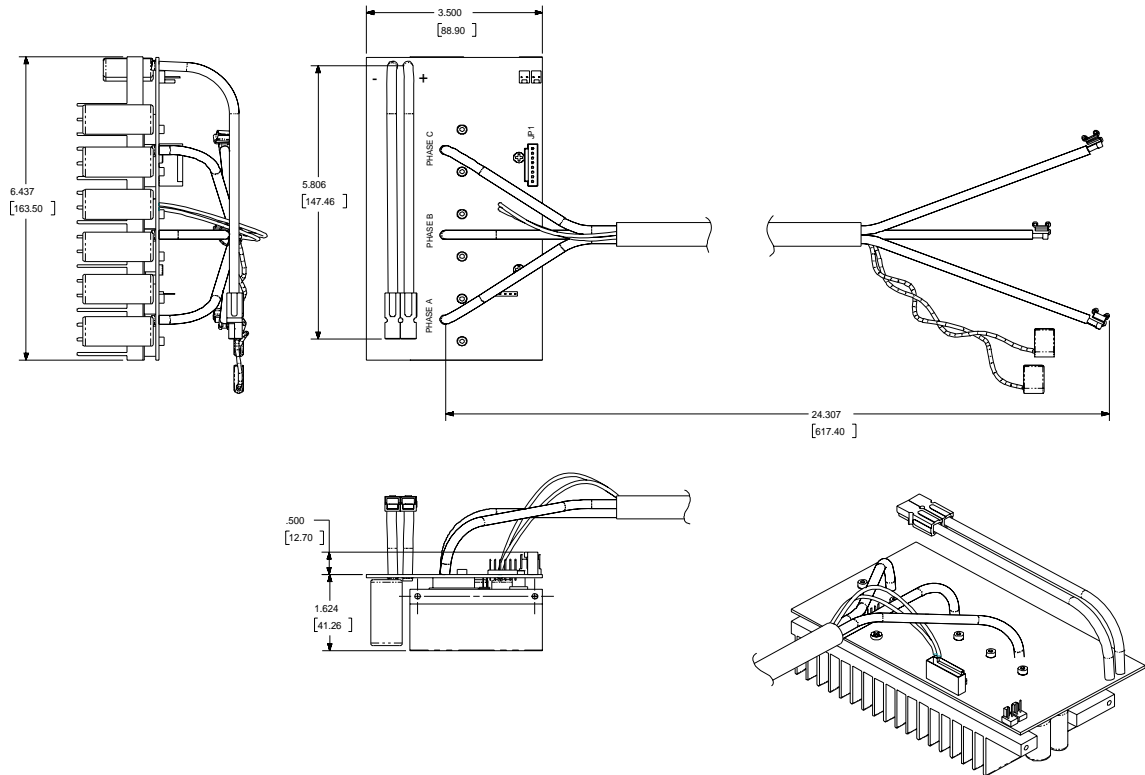

the Sierra

MASTERFLUX COMPRESSOR PERFORMANCE CHART (24V)
SIERRA03-0982Y3 High Capacity
Capacity (54.4° C Condenser) watt

rpm	Evaporator Temperature (° C)									
	-12.0	-9.4	-6.7	-3.9	-1.1	1.7	4.4	7.2	10.0	12.8
1800	471	512	567	634	713	805	910	1028	1159	1302
2300	641	699	773	862	967	1088	1224	1376	1544	1727
2800	805	861	940	1041	1164	1309	1477	1668	1881	2116
3800	1142	1243	1371	1528	1714	1928	2171	2442	2741	3070

Power Consumption (54.4° C Condenser) watt

rpm	Evaporator Temperature (° C)									
	-12.0	-9.4	-6.7	-3.9	-1.1	1.7	4.4	7.2	10.0	12.8
1800	340	355	368	380	390	398	405	411	415	418
2300	381	394	406	418	431	443	455	466	478	490
2800	432	448	465	482	499	517	535	554	573	592
3800	617	655	690	723	754	783	810	834	856	875

Current (54.4° C Condenser) amp

rpm	Evaporator Temperature (° C)									
	-12.0	-9.4	-6.7	-3.9	-1.1	1.7	4.4	7.2	10.0	12.8
1800	14.17	14.78	15.33	15.82	16.24	16.60	16.89	17.13	17.29	17.40
2300	15.89	16.41	16.92	17.43	17.94	18.44	18.94	19.44	19.92	20.41
2800	18.01	18.68	19.37	20.08	20.80	21.54	22.30	23.07	23.87	24.68
3800	25.70	27.28	28.76	30.14	31.43	32.63	33.73	34.74	35.65	36.47

COP (54.4° C Condenser) watt/watt

rpm	Evaporator Temperature (° C)									
	-12.0	-9.4	-6.7	-3.9	-1.1	1.7	4.4	7.2	10.0	12.8
1800	1.38	1.44	1.54	1.67	1.83	2.02	2.25	2.50	2.79	3.12
2300	1.68	1.78	1.90	2.06	2.25	2.46	2.69	2.95	3.23	3.53
2800	1.86	1.92	2.02	2.16	2.33	2.53	2.76	3.01	3.28	3.57
3800	1.85	1.90	1.99	2.11	2.27	2.46	2.68	2.93	3.20	3.51

Mass Flow (54.4° C Condenser) kg/hr

rpm	Evaporator Temperature (° C)									
	-12.0	-9.4	-6.7	-3.9	-1.1	1.7	4.4	7.2	10.0	12.8
1800	11.31	12.22	13.38	14.80	16.48	18.41	20.60	23.05	25.76	28.72
2300	15.25	16.58	18.20	20.13	22.36	24.89	27.71	30.84	34.27	38.00
2800	18.60	20.58	22.86	25.44	28.33	31.53	35.02	38.83	42.94	47.35
3800	26.09	28.50	31.41	34.83	38.75	43.18	48.11	53.55	59.49	65.94

* all data points are with 11.1° C superheat and 8.3° C subcooling

MASTERFLUX COMPRESSOR PERFORMANCE CHART (48V)
SIERRA03-0982Y3 High Capacity
Capacity (54.4° C Condenser) watt

rpm	Evaporator Temperature (° C)									
	-12.0	-9.4	-6.7	-3.9	-1.1	1.7	4.4	7.2	10.0	12.8
3700	1110	1241	1396	1575	1780	2009	2263	2542	2845	3174
4500	1459	1584	1745	1941	2174	2443	2747	3088	3464	3877
5300	1693	1856	2061	2306	2592	2919	3287	3696	4145	4636
6500	2448	2593	2789	3035	3332	3680	4078	4527	5027	5578

Power Consumption (54.4° C Condenser) watt

rpm	Evaporator Temperature (° C)									
	-12.0	-9.4	-6.7	-3.9	-1.1	1.7	4.4	7.2	10.0	12.8
3700	703	786	853	905	943	965	972	964	940	902
4500	939	996	1045	1086	1119	1143	1160	1168	1168	1160
5300	1099	1159	1215	1267	1315	1359	1399	1435	1466	1494
6500	1596	1681	1754	1814	1862	1897	1920	1931	1928	1914

Current (54.4° C Condenser) amp

rpm	Evaporator Temperature (° C)									
	-12.0	-9.4	-6.7	-3.9	-1.1	1.7	4.4	7.2	10.0	12.8
3700	14.66	16.37	17.77	18.86	19.64	20.10	20.24	20.07	19.59	18.80
4500	19.57	20.75	21.77	22.62	23.31	23.82	24.16	24.33	24.34	24.18
5300	22.89	24.14	25.31	26.39	27.39	28.31	29.14	29.89	30.55	31.13
6500	33.24	35.02	36.54	37.80	38.79	39.53	40.00	40.22	40.18	39.87

COP (54.4° C Condenser) watt/watt

rpm	Evaporator Temperature (° C)									
	-12.0	-9.4	-6.7	-3.9	-1.1	1.7	4.4	7.2	10.0	12.8
3700	1.58	1.58	1.64	1.74	1.89	2.08	2.33	2.64	3.03	3.52
4500	1.55	1.59	1.67	1.79	1.94	2.14	2.37	2.64	2.97	3.34
5300	1.54	1.60	1.70	1.82	1.97	2.15	2.35	2.58	2.83	3.10
6500	1.53	1.54	1.59	1.67	1.79	1.94	2.12	2.34	2.61	2.91

Mass Flow (54.4° C Condenser) kg/hr

rpm	Evaporator Temperature (° C)									
	-12.0	-9.4	-6.7	-3.9	-1.1	1.7	4.4	7.2	10.0	12.8
3700	26.04	29.04	32.46	36.31	40.58	45.28	50.40	55.95	61.92	68.31
4500	35.53	37.88	40.97	44.81	49.41	54.75	60.85	67.70	75.29	83.64
5300	42.52	45.02	48.47	52.86	58.21	64.50	71.74	79.93	89.07	99.16
6500	56.14	59.25	63.43	68.66	74.96	82.31	90.72	100.20	110.73	122.32

* all data points are with 11.1° C superheat and 8.3° C subcooling

MASTERFLUX COMPRESSOR PERFORMANCE CHART (24V)
SIERRA03-0982Y3 High Capacity

Capacity (130° F Condenser)										BTU/hr
	Evaporator Temperature (° F)									
rpm	10.0	15.0	20.0	25.0	30.0	35.0	40.0	45.0	50.0	55.0
1800	1608	1750	1935	2164	2436	2751	3109	3511	3957	4445
2300	2190	2388	2639	2944	3303	3715	4180	4699	5272	5898
2800	2749	2941	3209	3554	3975	4472	5046	5696	6422	7225
3800	3901	4244	4683	5220	5854	6585	7413	8339	9363	10483

Power Consumption (130° F Condenser)										watt
	Evaporator Temperature (° F)									
rpm	10.0	15.0	20.0	25.0	30.0	35.0	40.0	45.0	50.0	55.0
1800	340	355	368	380	390	398	405	411	415	418
2300	381	394	406	418	431	443	455	466	478	490
2800	432	448	465	482	499	517	535	554	573	592
3800	617	655	690	723	754	783	810	834	856	875

Current (130° F Condenser)										amp
	Evaporator Temperature (° F)									
rpm	10.0	15.0	20.0	25.0	30.0	35.0	40.0	45.0	50.0	55.0
1800	14.17	14.78	15.33	15.82	16.24	16.60	16.89	17.13	17.29	17.40
2300	15.89	16.41	16.92	17.43	17.94	18.44	18.94	19.44	19.92	20.41
2800	18.01	18.68	19.37	20.08	20.80	21.54	22.30	23.07	23.87	24.68
3800	25.70	27.28	28.76	30.14	31.43	32.63	33.73	34.74	35.65	36.47

EER (130° F Condenser)										BTU/h/watt
	Evaporator Temperature (° F)									
rpm	10.0	15.0	20.0	25.0	30.0	35.0	40.0	45.0	50.0	55.0
1800	4.73	4.93	5.26	5.70	6.25	6.91	7.67	8.54	9.53	10.65
2300	5.74	6.06	6.50	7.04	7.67	8.39	9.20	10.07	11.02	12.04
2800	6.36	6.56	6.90	7.38	7.96	8.65	9.43	10.29	11.21	12.20
3800	6.32	6.48	6.78	7.21	7.76	8.41	9.16	10.00	10.94	11.98

Mass Flow (130° F Condenser)										lb/hr
	Evaporator Temperature (° F)									
rpm	10.0	15.0	20.0	25.0	30.0	35.0	40.0	45.0	50.0	55.0
1800	24.94	26.93	29.50	32.63	36.32	40.59	45.42	50.82	56.78	63.31
2300	33.62	36.54	40.13	44.38	49.29	54.86	61.10	67.99	75.55	83.77
2800	41.02	45.37	50.39	56.09	62.46	69.50	77.21	85.60	94.66	104.39
3800	57.51	62.82	69.24	76.78	85.43	95.19	106.06	118.05	131.15	145.36

* all data points are with 20° F superheat and 15° F subcooling

MASTERFLUX COMPRESSOR PERFORMANCE CHART (48V)

SIERRA03-0982Y3 High Capacity

Capacity (130° F Condenser)										BTU/hr
	Evaporator Temperature (° F)									
rpm	10.0	15.0	20.0	25.0	30.0	35.0	40.0	45.0	50.0	55.0
3700	3792	4237	4766	5380	6078	6861	7729	8681	9717	10839
4500	4983	5409	5958	6630	7424	8342	9382	10545	11831	13239
5300	5781	6339	7037	7875	8852	9969	11225	12621	14157	15832
6500	8362	8856	9524	10365	11379	12566	13927	15461	17168	19049

Power Consumption (130° F Condenser)										watt
	Evaporator Temperature (° F)									
rpm	10.0	15.0	20.0	25.0	30.0	35.0	40.0	45.0	50.0	55.0
3700	703	786	853	905	943	965	972	964	940	902
4500	939	996	1045	1086	1119	1143	1160	1168	1168	1160
5300	1099	1159	1215	1267	1315	1359	1399	1435	1466	1494
6500	1596	1681	1754	1814	1862	1897	1920	1931	1928	1914

Current (130° F Condenser)										amp
	Evaporator Temperature (° F)									
rpm	10.0	15.0	20.0	25.0	30.0	35.0	40.0	45.0	50.0	55.0
3700	14.66	16.37	17.77	18.86	19.64	20.10	20.24	20.07	19.59	18.80
4500	19.57	20.75	21.77	22.62	23.31	23.82	24.16	24.33	24.34	24.18
5300	22.89	24.14	25.31	26.39	27.39	28.31	29.14	29.89	30.55	31.13
6500	33.24	35.02	36.54	37.80	38.79	39.53	40.00	40.22	40.18	39.87

EER (130° F Condenser)										BTU/h/watt
	Evaporator Temperature (° F)									
rpm	10.0	15.0	20.0	25.0	30.0	35.0	40.0	45.0	50.0	55.0
3700	5.39	5.39	5.59	5.94	6.45	7.11	7.95	9.01	10.33	12.01
4500	5.31	5.43	5.70	6.10	6.64	7.30	8.09	9.03	10.13	11.41
5300	5.26	5.47	5.79	6.22	6.73	7.34	8.03	8.80	9.65	10.59
6500	5.24	5.27	5.43	5.71	6.11	6.62	7.25	8.01	8.90	9.95

Mass Flow (130° F Condenser)										lb/hr
	Evaporator Temperature (° F)									
rpm	10.0	15.0	20.0	25.0	30.0	35.0	40.0	45.0	50.0	55.0
3700	57.41	64.02	71.57	80.05	89.47	99.82	111.11	123.34	136.51	150.60
4500	78.34	83.50	90.32	98.80	108.93	120.71	134.15	149.24	165.99	184.40
5300	93.73	99.25	106.85	116.54	128.33	142.20	158.17	176.22	196.37	218.60
6500	123.77	130.63	139.84	151.37	165.25	181.46	200.01	220.89	244.11	269.67

* all data points are with 20° F superheat and 15° F subcooling