

## Step #1

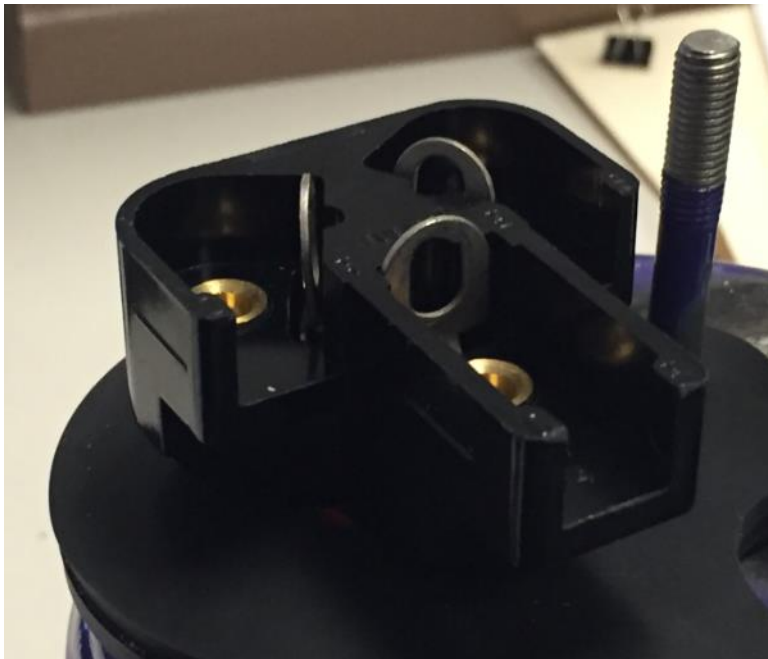

Figure 1

- Set the connector block over the terminals feeding each terminal through the designated slot as shown in Figure 1

# Connector Block

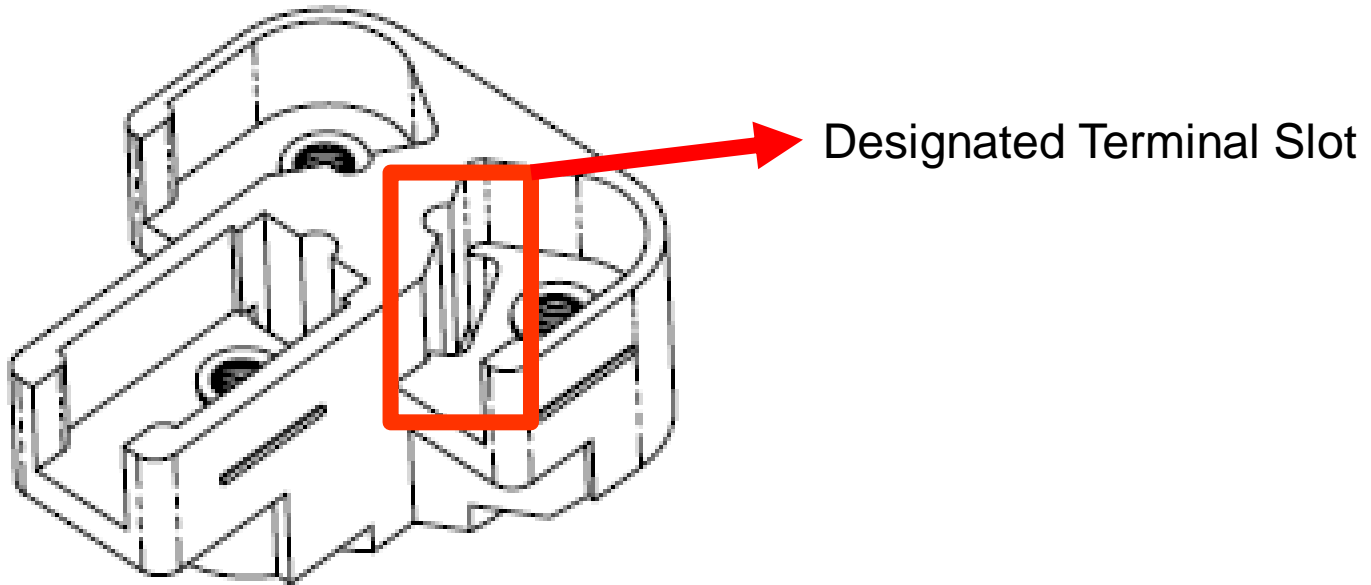

Figure 2

## Step #2



Figure 3

- Fold down each terminal down so that they are flush with the screw hole; shown in Figure 3.

## Step #3

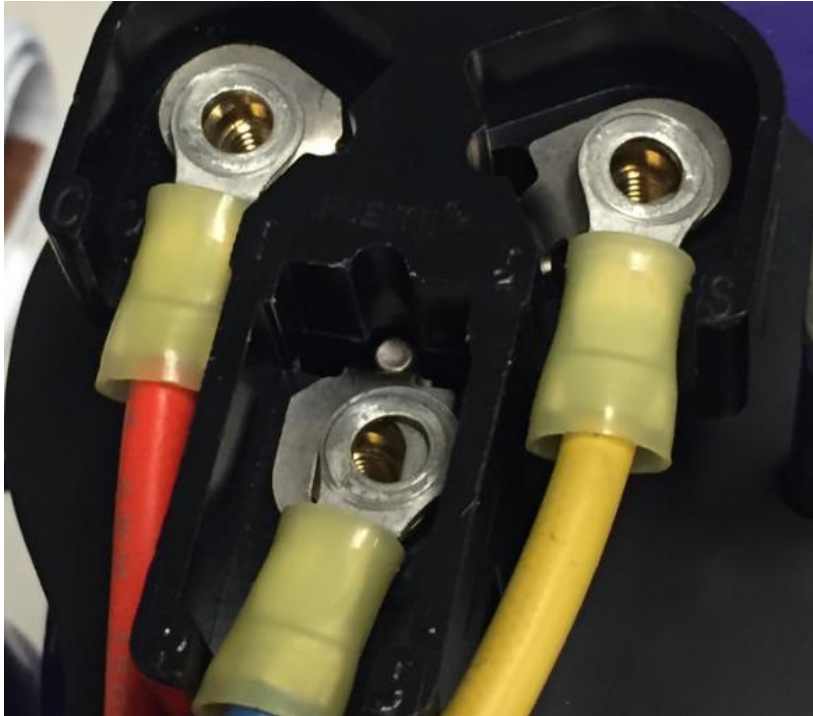

- Place the harness ring terminals on top of the folded over compressor terminals; shown in Figure 4

Figure 4

## Step #4

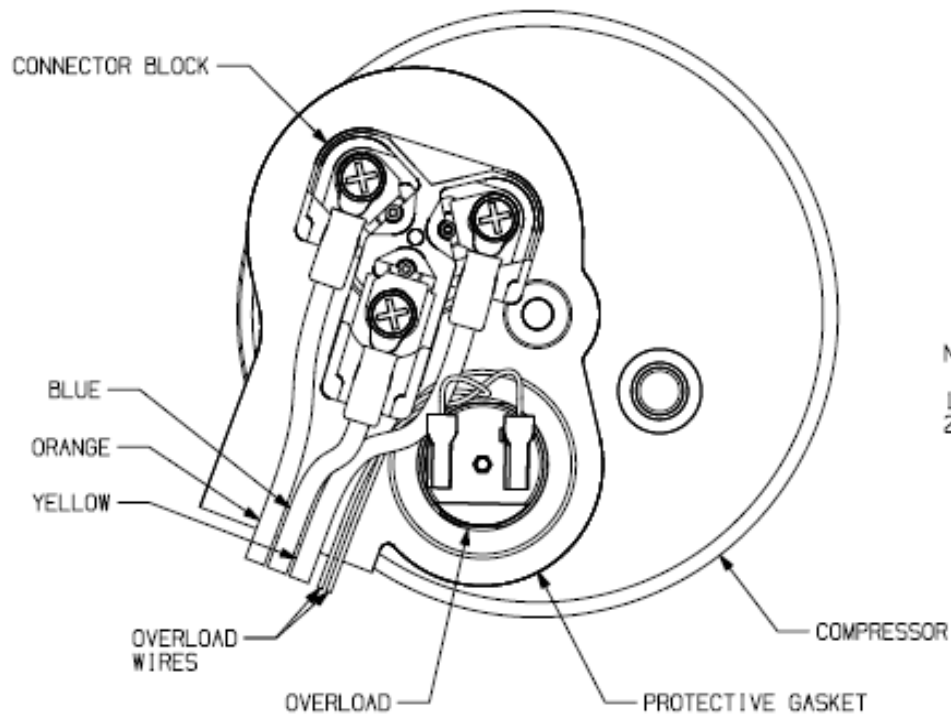

Figure 5

- Fasten the harness to the connector block with #10-32 or M5 screws. Screws should be selected to match the threaded inserts in the connector block. Metric connector block will have "M5" marking in the terminal slot.

# Terminal Drawing

FOLD OVER TERMINAL STYLE



NOTES:

1. TORQUE #10-32 SCREWS TO 12-18 IN-LBS.
2. TORQUE M5 SCREWS TO 1.5-2.2 N-m.